

EVERPURE® SOLARIA®

SOLARIA APPLIANCE FOR INSTANT HOT WATER

Get luxurious instant hot water at the tap with the Everpure® Solaria® Instant Hot Water Appliance. The perfect complement to an Everpure commercial grade water filtration system, the Solaria delivers great tasting, piping hot water on demand. This unit offers a generous capacity of up to 100 cups of water per hour at 190°F. The Solaria is a compact unit that provides instant hot water from your tap for coffee, tea, hot chocolate, oatmeal, pasta, soups and much more.

FEATURES

- Dispenses piping hot water on demand
- Compact unit is easy to hide in any kitchen cabinet or wet bar
- Powder coated, insulated stainless steel tank is energy efficient and maintenance free
- Easy-to-install with quick connect fittings and drain plug



- Fingertip temperature adjustment
- Automatic shut-off which prevents accidental dry starts and prevents misuse
- Non-pressurized tank with self contained expansion chamber

SPECIFICATIONS

- | | |
|---|---|
| • Dimensions
6.8W x 11.2H x 8.1D in | • Power
1300 watts |
| • Capacity
100 cups per hour | • Motor compressor
120 volts, 60 Hz |
| • Tank volume
5/8 gallon | |
| • Temperature output
140° F - 190° F | |
| • Inlet/outlet
3/8" Outer dimension tubes | |

ORDERING INFORMATION



MODEL	PART NO	DESCRIPTION
Solaria®	EV931840	Hot water appliance

GENERAL INSTALLATION / OPERATION / MAINTENANCE REQUIREMENTS

Not recommended for use with a Reverse Osmosis (RO) water filtration system – eventual damage to the pump will result. To prevent damage, install with a booster pump or autoclave.

Install the appliance away from heat sources and direct sunlight.

Do not install the appliance outdoors or in damp locations.

Minimum installation space – 2.5 inches from adjacent surfaces for proper air circulation around appliance.

The appliance generates heat, so external venting may be required when it is installed in a cabinet.

DRINKING WATER FAUCETS

Faucet and filtration system sold separately. Vented faucet required.

DIMENSIONS

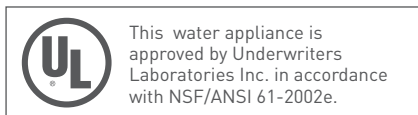
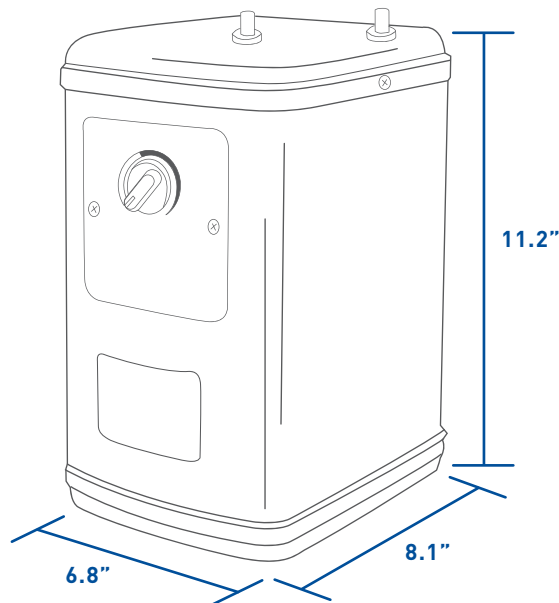

FILTRATION & PROCESS

5730 NORTH GLEN PARK ROAD, MILWAUKEE, WI 53209
P: 262.238.4400 | F: 262.238.4404 | WWW.PENTAIRAQUA.COM | WWW.RESIDENTIAL.EVERPURE.COM | CUSTOMER CARE: 800.279.9404

All Pentair trademarks and logos are owned by Pentair, Inc. or its affiliates. All other registered and unregistered trademarks and logos are the property of their respective owners. Because we are continuously improving our products and services, Pentair reserves the right to change specifications without prior notice. Pentair is an equal opportunity employer.

4002835 REV B JL14 © 2014 Pentair Residential Filtration, LLC. All Rights Reserved.